

ASSEMBLY INSTRUCTIONS

REVISIONS		DATE
REV.	DESCRIPTION	
A	INITIAL RELEASE	

1. Select the straightest lumber possible.
 2. Drill and cut 2 1/2" x 3" long slots into Item 7 (2 x 8 Beam) in locations shown.
Bore 1/2" dia hole through Item 7 (Beam) in location shown. Hole should continue through slot cut in previous step.
 3. Drill 3/16" dia holes through Item 8 (1 1/4" EMT metal conduit) in locations shown, 9 places. (Next step is optional) counter bore on one side with 3/8" dia hole. This will allow the screw to capture the pipe on the inside rather than the outside of the pipe. If you choose not to you will have to grind and smooth the screw heads to the surface of the pipe. Drill 1/2" dia holes in Item 8 (EMT conduit) in locations shown.
 4. Using Item 6 (#6 wood screws) secure Item 8 (Conduit) to the bottom edge and on center of Item 7 (Beam) as shown in assembly detail.
 5. Center Item 9 (2 x 4 Cap) on top edge of Item 7 (Beam) and secure using Item 6 (#6 wood screws) as shown.
 6. Drill 1/2" dia holes into Item 11 (2 x 10 Press Base) in locations shown.
 7. Drill and insert Item 5 (Drop-In Anchor) into concrete floor using 1/2" diameter holes in Item 11 (Base) for location, 2 places.
 8. Secure Item 4 (3/8 - 16 All Thread) into Item 5, 2 places.
 9. Place Item 11 (Base) over Item 4 through the previously drilled 1/2" diameter holes. Position press rail assembly over Item 4 so as to rest on top of Item 11 (Press Base).
 10. Located and secure Item 10 (Base Side Rails) to Item 11 (Press Base) leaving 1/16" gap between Item 8 (EMT Conduit) and the Base Rails, 2 places.
- NOTE: This dimension may vary. Adjust to achieve final skin bend angle of 85 degrees.
11. Add hardware Items 1,2,3 as shown in assembly.

TIPS:

- Remove all burrs and dings in both the conduit and the Base Rails before use.
- Lubricate both the conduit and Base Rails with screw wax or grease.
- When removing skin from press slowly back off of the clamping nuts in 1 to 2 inch increments and pull skin up between steps. If the skin is allowed to pop out all at once it will most likely bend.
- Use 2x4 blocks on the end to keep the beam in place while you slide the skin into position.
- Mark 1" on both sides of skin centerline. This will help you align the skin after the conduit covers up your centerline.

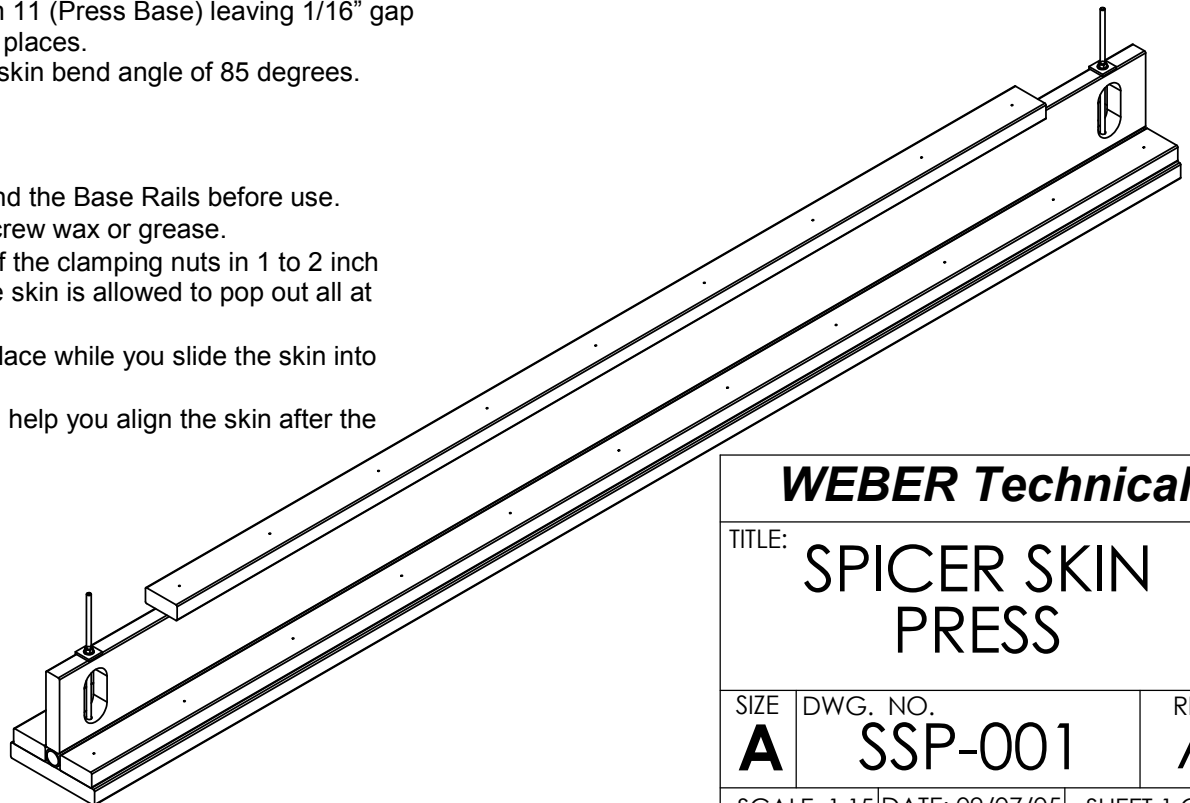

WEBER Technical

TITLE:
**SPICER SKIN
PRESS**

SIZE A	DWG. NO. SSP-001	REV A
------------------	----------------------------	-----------------

SCALE: 1:15 | DATE: 09/07/05 | SHEET 1 OF 7

5

4

3

2

1